

# HYDROVANE HV04 USER HANDBOOK MANUAL



User Handbook

## **HV04 - HV45 Models (ACE)**

**Stationary Air Compressors**



Contents

- 1 Introduction . . . . . 1**
- 1.1 Support . . . . . 1
- 1.2 Customer Warranty Terms . . . . . 1
- 1.3 Product Development . . . . . 1
- 1.4 Quality Standards . . . . . 1
- 1.5 Model Range . . . . . 1
- 1.6 Product Terminology . . . . . 2
- 2 Safety . . . . . 3**
- 2.1 General Health and Safety Precautions . . . . . 3
- 2.2 The Health and Safety at Work Act, 1974 . . . . . 3
- 2.3 Before Working on Compressor . . . . . 3
- 2.4 When Operating the Compressor . . . . . 3
- 2.5 Potential Oil Health Hazards . . . . . 4
- 2.6 First Aid Measures . . . . . 4
- 2.7 Warnings, Cautions and Notes . . . . . 4
- 3 Product Information . . . . . 5**
- 3.1 Operating Temperatures . . . . . 5
- 3.2 High Operating Temperatures . . . . . 5
- 3.3 Noise Level . . . . . 5
- 3.4 Technical Data HV04-HV07 . . . . . 6
- 3.5 Technical Data HV11-HV22 . . . . . 7
- 3.6 Technical Data HV30-HV45 . . . . . 8
- 4 Transportation and Handling . . . . . 9**
- 4.1 Introduction . . . . . 9
- 4.2 Lifting and Handling (Fig. 4.1 and Fig. 4.2) . . . . . 9
- 4.3 Model Weights . . . . . 9
- 5 Installation and Commissioning . . . . . 11**
- 5.1 Positioning Your Compressor - Basic Requirements . . . . . 11
- 5.2 Ventilation (Fig. 5.1) . . . . . 11
- 5.3 Electrical Connections . . . . . 11
- 5.4 Electrical Installation (Fig. 5.2) . . . . . 12
- 5.5 Check Direction of Motor Rotation . . . . . 12
- 5.6 Regulated Speed Compressor Installation . . . . . 12
- 5.7 RS Operation with other Hydrovane Compressors . . . . . 13
- 6 General Description . . . . . 15**
- 6.1 Compressor/Hypac (Fig. 6.1) . . . . . 15
- 6.2 Control Systems . . . . . 15
- 6.3 Compressor Assembly (Fig. 6.2) . . . . . 16
- 6.4 Electronic Controller . . . . . 16
- 7 Operating Instructions . . . . . 17**
- 7.1 Introduction . . . . . 17
- 7.1.1 Checking Procedure Before Starting . . . . . 17
- 7.1.2 Compressor Operation . . . . . 17
- 7.1.3 Starting - Automatic Mode . . . . . 18
- 7.1.4 Starting - Continuous Mode . . . . . 18
- 7.1.5 Starting - Regulated Speed . . . . . 18
- 7.1.6 Stopping – All Models . . . . . 18
- 7.1.7 Emergency Stop . . . . . 18
- 7.1.8 Compressor Vent Down . . . . . 18
- 7.2 Operational Display Symbols . . . . . 19

(continued)

**Contents (continued)**

7.3 LED Indicators (Fig 7.2) .....19

**8 Adjustments .....21**

8.1 Compressor Control (Fig. 8.1) .....21

8.2 Customer Menu (P10) .....21

8.3 Operating Mode (AUT/MO) .....21

8.4 Pressure Adjustment - Single Speed .....21

8.5 Pressure Control - RS Compressors .....22

8.6 Servo Valve (Fig. 8.2) .....22

**9 Servicing .....23**

9.1 Introduction .....23

9.2 Routine Service Schedule .....23

9.3 Servicing (RS) .....23

9.4 Check Compressor Operation .....23

9.4.1 Check Compressor Pressure .....23

9.4.2 Check oil level (Fig. 9.1) .....23

9.5 Basic Service .....24

9.6 Access Panel Removal .....24

9.7 Oil Draining and Filter Replacement (Fig. 9.2 and Fig. 9.3) .....24

9.8 Oil Draining .....24

9.9 Oil Filter Replacement (Fig. 9.3) .....24

9.10 Oil filling / Top-up (Fig. 9.3) .....25

9.11 Air Filter Replacement (Fig. 9.2) .....25

9.12 Oil Separator Replacement (Fig. 9.2) .....25

9.13 Clean Oil Cooler/Aftercooler (Fig. 9.4) .....25

9.14 Cabinet Air Filter .....25

9.15 Panel Refitting .....25

9.16 Electrical Checks .....25

9.17 Motor Cleaning .....25

9.18 Servicing Requirements .....26

9.19 Service Schedule: Fluid Force Red, Clear and HPO Oil .....26

9.20 Service Kits .....26

**10 Fault Finding .....29**

10.1 Fault Finding .....29

10.2 Shutdown Error (E) .....29

10.3 Alarm Error (A) .....29

10.4 Run Inhibit Error (R) .....29

10.5 Service Alarm Error (A) .....29

10.6 Fault Display Symbols .....29

10.7 Controller Menus .....30

10.8 Oil Change Service Menu - P20 .....30

10.9 Service Engineers Menu - P21 .....30

10.10 Diagnostic Menu - P22 .....30

10.11 Drive Configuration Menu - P30 .....30

10.12 Factory Menu - P31 .....30

## 1 Introduction

### IMPORTANT !

**BEFORE INITIAL START-UP, ENSURE THE COMPRESSOR IS FILLED WITH A HYDROVANE APPROVED OIL. DO NOT OVERFILL.**

### 1.1 Support

Full support is available from your Hydrovane Distributor. If you need any specialist help or service, please contact your Distributor quoting the MODEL, TYPE and SERIAL NUMBER.

### 1.2 Customer Warranty Terms

All compressors, which are serviced by an authorised Hydrovane Distributor, are guaranteed for 12 months from commissioning or 18 months from the date of shipment.

The warranty excludes normal service parts, oil and wear items, dirt ingress, cleaning of filters and fluid drain devices and the tightening of electrical or other connections. Also excluded is adjustment of the controller settings. Consequential damage of any nature is not covered by the warranty.

An 'Advance' 10 year warranty is available for approved installations, contact your Hydrovane Distributor for details.

### 1.3 Product Development

Hydrovane adopt a policy of continual product development. The information in this handbook, whilst fully up to date when issued, may be subject to change without notice.

### 1.4 Quality Standards

Hydrovane Quality Management Systems are approved to BS EN ISO 9001.

These instructions comply with the latest European Directives regarding content and are valid for machines carrying the CE mark.

Gardner Denver Ltd  
Claybrook Drive  
Washford Industrial Estate  
Redditch  
Worcestershire B98 0DS  
United Kingdom

Tel: +44 (0)1527 525522  
Fax: +44 (0)1527 521140

Web: [www.hydrovane.co.uk](http://www.hydrovane.co.uk)  
[www.hydrovane@compair.com](mailto:www.hydrovane@compair.com)  
[www.compair.com](http://www.compair.com)

E-mail: [sales@compair.com](mailto:sales@compair.com)

### 1.5 Model Range

This Handbook relates to all ACE HV04-HV45 vertical range compressors and hypac models.

V04ACE07-4035D400	50Hz model
V04ACE10-4035D400	50Hz model
V04ACE07-4035S400	50Hz model
V04ACE10-4035S400	50Hz model
V04ACE07-2336D405	60Hz model
V04ACE10-2336D405	60Hz model
V04ACE07-2316D405	60Hz model
V04ACE10-2316D405	60Hz model
V04ACE07-5756D405	60Hz model
V04ACE10-5756D405	60Hz model
V05ACE07-4035D400	50Hz model
V05ACE10-4035D400	50Hz model
V05ACE07-4035S400	50Hz model
V05ACE10-4035S400	50Hz model
V05ACE07-2336D405	60Hz model
V05ACE10-2336D405	60Hz model
V05ACE07-2316D405	60Hz model
V05ACE10-2316D405	60Hz model
V05ACE07-5756D405	60Hz model
V05ACE10-5756D405	60Hz model
V07ACE07-4035S400	50Hz model
V07ACE10-4035S400	50Hz model
V07ACE07-2336D405	60Hz model
V07ACE10-2336D405	60Hz model
V07ACE07-4035V400	50/60Hz model
V07ACE07-5756D405	60Hz model
V07ACE10-5756D405	60Hz model
V11ACE08-4035S400	50Hz model
V11ACE10-4035S400	50Hz model
V11ACE08-2336D405	60Hz model
V11ACE10-2336D405	60Hz model
V11ACE08-5736D405	60Hz model
V11ACE10-5736D405	60Hz model
V11ACE08-4035V400	50/60Hz model
V11ACE08-2035V400	50/60Hz model
V15ACE08-4035S400	50Hz model
V15ACE10-4035S400	50Hz model
V15ACE08-2336D405	60Hz model
V15ACE10-2336D405	60Hz model
V15ACE08-5736D405	60Hz model
V15ACE10-5736D405	60Hz model
V15ACE08-4035V400	50/60Hz model
V15ACE08-2035V400	50/60Hz model
V18ACE08-4035S200	50Hz model
V18ACE10-4035S200	50Hz model
V18ACE08-2336D205	60Hz model
V18ACE10-2336D205	60Hz model
V18ACE08-5736D205	60Hz model
V18ACE10-5736D205	60Hz model
V18ACE08-4035V200	50/60Hz model
V18ACE08-2035V200	50/60Hz model
V22ACE08-4035S200	50Hz model
V22ACE10-4035S200	50Hz model
V22ACE08-2336D205	60Hz model
V22ACE10-2336D205	60Hz model
V22ACE08-5736D205	60Hz model
V22ACE10-5736D205	60Hz model

V22ACE08-4035V200	50/60Hz model
V22ACE08-2035V200	50/60Hz model
V30ACE08-4035S150	50Hz model
V30ACE10-4035S150	50Hz model
V30ACE08-4035V150	50Hz model
V30ACE08-4636V150	60Hz model
V30ACE08-2036D150	60Hz model
V30ACE10-2036D150	60Hz model
V30ACE08-5736D150	60Hz model
V30ACE10-5736D150	60Hz model
V37ACE08-4035S150	50Hz model
V37ACE10-4035S150	50Hz model
V37ACE08-4035V150	50Hz model
V37ACE08-4636V150	60Hz model
V37ACE08-2036D150	60Hz model
V37ACE10-2036D150	60Hz model
V37ACE08-5736D150	60Hz model
V37ACE10-5736D150	60Hz model
V45ACE08-4035S150	50Hz model
V45ACE10-4035S150	50Hz model
V45ACE08-4035V150	50Hz model
V45ACE08-4636V150	60Hz model
V45ACE08-2036D150	60Hz model
V45ACE10-2036D150	60Hz model
V45ACE08-5736D150	60Hz model
V45ACE10-5736D150	60Hz model

The last three digits of the product code represent mark number changes, you may receive a unit with numbers higher than those shown above.

### 1.6 Product Terminology

The product code segments signifies:

V	Vane
04, 05, 07, 11, 15, 18, 22, 30, 37, 45	kW motor
ACE	Air Centre Electronic
07, 08, 10	Delivery pressure in bars
20, 23,40, 46, 57	Voltage, tri-rated motors
1, 3	Single or three phase
5, 6	50 or 60Hz
D, S, V	Direct On Line, Star/Delta, Variable Speed
000,100,200,300	Revision number European (50 Hz)
005,105,205,305	Revision number USA (60 Hz)

This publication refers to compressors with serial numbers from:

- V04-001507-0812
- V05-001272-0901
- V07-003863-0901
- 
- V11-000839-0901
- V15-000949-0901
- 
- V18-000190-0901
- V22-000685-0901
- 
- V30-000075-0902
- V37-000120-0902
- V45-000069-0902

## 2 Safety

### 2.1 General Health and Safety Precautions

**Please read carefully and proceed in accordance with the following instructions before installation, operation, maintenance or repair of the compressor unit.**

### 2.2 The Health and Safety at Work Act, 1974

In order to comply with your responsibilities under the above act, it is essential that the compressor is transported, positioned, installed, operated and maintained by competent persons in accordance with the instructions in this handbook.

The standard build of all Hydrovane products are designed to compress clean, dry, atmospheric air and are not intended for use in either Explosive or Potentially Explosive Atmospheres as defined in the ATEX Directive 94/9/EC.

A potentially Explosive atmosphere is an atmosphere which could become explosive due to local and operational conditions.

The compressor warranty will be invalidated if unapproved spare parts or oils are used. Using such items may cause the efficiency and service life of the compressor to be reduced, and could create a hazardous condition over which Hydrovane has no control.

Failure to maintain the compressor correctly, or modifying it without prior approval from Hydrovane, may also create a hazardous condition. This will also invalidate the warranty.

Read and fully understand the contents contained in the User Handbook.

Ensure that the User Handbook is not permanently removed from the compressor.

Check that there are no signs of damage and/or oil leaks from the compressor, cooler and associated pipework.

After completing work, tools and foreign matter should be removed from the compressor and its surrounding area.

In the unlikely event of a compressor fire, dry powder or carbon dioxide fire extinguishers should be used. Never use water.

### 2.3 Before Working on Compressor

Potentially dangerous voltages are used to power this machine. Do not carry out any work until the isolator is locked in the off position. Fit a safety notice to the isolator advising that work is being carried out and that the isolator must not be switched on. If in doubt, a qualified electrician may remove the fuses and keep them in a secure place until work is complete.

Ensure the compressor has been safely isolated from the main air system and cannot be re-introduced until all work has been completed. Fit a safety notice to the isolation valve advising that work is being carried out.

Do not undertake any work until the compressor and receiver, if fitted, have been relieved of all pressure.

Wait until the compressor's vent down cycle is complete.

Release any pressure contained in the aftercooler or associated pipework.

Check that the compressor pressure gauge reads zero. Do not proceed until it does.

Carefully unscrew the compressor filler plug. If any air or oil escapes before the plug is fully removed stop! Do not remove the plug until all pressure is lost.

Safety devices fitted to the compressor or pipework system should be checked at regular intervals and replaced if faulty. They should not be tampered with or modified. Non return valves should not be used as isolation devices.

To ensure the compressor operates safely you must carry out the specified maintenance procedures.

Only approved oils should be used for flushing purposes.

Extreme caution should be taken if the compressor has been subjected to severe operating temperatures or fire. Certain components may contain fluoroelastomer materials and under these conditions can leave extremely corrosive residues. Severe burns and permanent skin and tissue damage can be a result of skin contact.

The Health and Safety information contained in this Handbook is only intended to give general guidelines.

### 2.4 When Operating the Compressor

When in automatic mode the compressor may restart without warning.

Additional warnings will be required if the unit is configured for remote stop/start or to restart after power failure.

Do not remove any plugs or release pipework when the compressor is running.

Do not attempt to open the starter enclosure while the compressor is operating.

Beware of hot surfaces, both the compressor and electric motor are designed to run at elevated temperatures.

Compressed air is potentially dangerous and can be fatal if misused. Do not allow compressed air jets, discharged from any pipe or nozzle, to make contact with your body.

Wear safety glasses and suitable clothing when using or working in an area where compressed air is being used.

Hazardous vapours/fumes can be produced if compressed air is used to remove chemicals, cleaning agents and oils from equipment and components. Suitable respiratory and extraction equipment may be required in these circumstances. Never use compressed air for cleaning personal clothing.

Air discharged from compressors is unsuitable for breathing purposes. Air for human consumption must be subjected to further treatment to ensure that contaminant levels for odour and moisture content meet the requirements of BS 4275 1974.

We recommend that air supply to hand-held air guns is regulated to a lower pressure (refer to local Health and Safety regulations).

Do not insert any object or any part of your body through any opening of the compressor enclosure. Serious personal injury and/or damage may result.

Never run the compressor with any covers or guards missing, unless advised to do so.

### 2.5 Potential Oil Health Hazards

This section relates to Hydrovane approved oil. For other oils refer to the Health and Safety Instructions issued with the relevant product.

There are no significant hazards associated with this product when properly used and in the application for which it was designed. Frequent and/or prolonged skin contact may give rise to skin irritations and it is recommended that protective gloves are worn. The carcinogenic action of mineral oils should be brought to the attention of all users. \*

The oil may be hot so take care when carrying out oil changes.

Do not keep oily rags in pockets or wear contaminated clothing. Do not inhale fumes or vapours. Do not swallow. Avoid eye contact.

Always wash hands after use and before eating, drinking and smoking.

### 2.6 First Aid Measures

Inhalation - Remove from exposure into fresh air. If necessary give artificial respiration or oxygen. Seek medical advice.

Skin Contact - \*Mildly irritating. Remove by wiping. Wash with soap and water. Apply emollient cream.

Eye Contact - \*Mildly irritating. Flush with copious amounts of warm water. Seek medical advice if necessary.

Ingestion - Do not induce vomiting because of the risk of aspiration. Wash mouth out with water. Give 200-300 ml (1/2 a pint) milk. Seek immediate medical attention.

#### Further Medical Treatment

Aspiration - If there is any suspicion of aspiration into the lungs (for example during vomiting) admit to hospital immediately.

Pressure injection - Obtain immediate medical attention, even if injury appears minor.













Spillage - Soak up with absorbent clay.

Waste Disposal - Oil, condensate, filter elements etc. should be disposed of in accordance with local regulations. Do not allow oil to contaminate water supplies.

\* See Cautionary Notice SHW 397 'Effects of Mineral Oil on the Skin' and MS(B) 5 'Skin Cancer Caused by Oil' published by the Health and Safety Executive.

### 2.7 Warnings, Cautions and Notes

**WARNING !** is used in the text to identify specific hazards which can cause injury or death. This type of hazard is identified below.

-  Risk of electric shock
-  Risk of hazard or danger
-  Risk of hot surfaces
-  Eye protection must be worn
-  Dust protection must be worn
-  Warning pressurised vessel
-  Warning pressurised component or system
-  Warning unit is remotely controlled and may start without warning
-  Read the instruction manual
-  Do not operate the machine without the guard being fitted
-  Warning do not start the machine without consulting Handbook
-  Lifting point
-  Direction of rotation

**CAUTION !** is used in the text to identify incorrect procedures which can cause damage to the compressor.

**NOTE !** is used in the text to draw attention to specific points of importance.

Hydrovane declines all liability in the event of material damage or bodily injury resulting from negligence in the application of these precautions, from non-observation or lack of elementary supervision in respect of handling, operation, servicing or repair, even if not expressly stated in this instruction notice.

### 3 Product Information

#### 3.1 Operating Temperatures

Your compressor will give optimum performance and trouble-free service life when the bulk oil temperature is maintained between 75°C and 85°C.

Certain operating conditions sustained over a period of time may cause problems that effect the performance and reliability of this compressor.

Problems may occur when compressors run for short periods on low air demand where they don't reach normal operating temperatures.

Prolonged use under these conditions can cause condensation build up within the compressor and may eventually lead to emulsification of the oil.

Normal operating temperatures are reached in typically 10/15 minutes. To purge condensate from the compressor, a longer running period with a high air demand is needed, usually a minimum of 60 minutes will be required.

Conditions or applications which prevent the compressor temperature stabilising between these parameters should be avoided.

Single speed HV30-HV45 and all RS units have automatic stop/start cooling fans that cut in at 85°C operating temperature.

Consult your local Hydrovane Distributor if you have any particular concerns about operational characteristics of your compressor.

#### 3.2 High Operating Temperatures

Some of the reasons for high compressor oil temperatures are:

- Low oil level.
- Blocked oil cooler or cooler flow restrictions.
- Wrong type or grade of oil.
- High ambient temperature.
- Cooling fan stopped or operating incorrectly.

**NOTE !** The controller display will show a warning when the compressor temperature reaches 107°C.

**NOTE !** The compressor will stop automatically if the temperature rises above 110°C.

If the bulk oil temperature frequently reads 100°C, then Fluid Force HPO oil should be used.

#### 3.3 Noise Level

Although the sound pressure level for these units is relatively low, they should be positioned where noise will not be a problem.

**3.4 Technical Data HV04-HV07**

Model Number	HV04	HV05	HV07	HV07RS
<b>PERFORMANCE</b>				
F.A.D. litres/sec (cfm) @ 7 bar	11 (24)	15 (32)	21 (44)	
F.A.D. litres/sec (cfm) @ 10 bar	9 (20)	12 (25)	17 (35)	
F.A.D. litres/sec (cfm) @ 6 bar				0-22 (0-46)
Noise Level - dBA	66	66	67	
Power - kW (hp)	4 (5.5)	5.5 (7.5)	7.5 (10)	
Starter Type	Automatic DOL & SD			Inverter Soft Start
Drive Type	Direct			
Operating Controls	Continuous Run, Automatic Stop/Start, Reduced Energy Vent System			Variable
Rotation Speed - rev/min 50Hz (60 Hz)	1450 (1760)			990-2130
Ambient Temperature Range °C	0 to 45			0 to 40
Maximum Relative Humidity %	85 non-condensing			
Air Discharge Temp - °C (above ambient)	<6	<8	<10	
<b>FACTORY SETTINGS</b>				
Nominal Pressure - bar	7.0 or 10.0			7.0
Minimum Pressure Valve - bar	5.5 to 6.0			
Load Pressure - bar (PL)	6.5 or 9.5			7.0
Unload Pressure - bar (PU)	7.5 or 10.5			7.5
Servo Valve - bar	8.0 or 11.0			8.0
Run-on Time after PU - secs (RT)	120			60
Run-on-Time to Stop - secs (ST)	2			
Pressure Display Units (P>)	0 (bar) (1 = psi, 2 = kpa)			
Temperature Display Units (T>)	0 = °C (1 = °F)			
Vacuum Relief Valve	1.5 turns anti-clockwise			
<b>INSTALLATION</b>				
ACE Dimensions D x W x H -mm	635 x 500 x 1050			
Air Outlet Size - Rp	3/4			
Minimum Room Volume - m <sup>3</sup>	15			
Air Inlet/Outlet Area - m <sup>2</sup>	0.3			
Ventilation Rate - m <sup>3</sup> /h	2000			
Cooling Air Flow m <sup>3</sup> /h (cfm)	1850 (1089)			
Recommended Air Receiver Capacity - L	250			
<b>COMPRESSOR OIL</b>				
Approved compressor oil	Fluid Force Red 2000 (Mineral) & HPO (Synthetic)			
Oil Capacity - litres	3			
<b>ELECTRICAL</b>				
Starter reference 400V 50Hz DOL	35121			
Circuit diagram 400V 50Hz DOL	77319			
Starter reference 400V 50Hz SD	35120			
Circuit diagram 400V 50Hz SD	77318			
Starter reference 400/460V 50/60Hz RS				35124
Circuit diagram 400/460V 50/60Hz RS				77117
Starter reference 200-575V 60Hz DOL 3PH	35122			
Circuit diagram 200-575V 60Hz DOL 3PH	77320			
Starter reference 230V 60Hz DOL 1PH	35123			
Circuit diagram 230V 60Hz DOL 1PH	77321			

#### 3.5 Technical Data HV11-HV22

Model Number	HV11	HV15	HV18	HV22	HV11RS	HV15RS	HV18RS	HV22RS
<b>PERFORMANCE</b>								
F.A.D. litres/sec (cfm) @ 8 bar	29 (61)	38 (81)	49(104)	60(127)				
F.A.D. litres/sec (cfm) @ 10 bar	25 (52)	33 (71)	42 (90)	52(110)				
F.A.D. litres/sec (cfm) @ 6 bar					31 (66)	41 (87)	52 (110)	65 (137)
Noise Level - dBA	69	70	70	71	69	70	70	71
Power - kW (hp)	11 (15)	15 (20)	18 (25)	22 (30)	11 (15)	15 (20)	18 (25)	22 (30)
Starter Type	Automatic DOL & SD				Inverter Soft Start			
Drive Type	Direct							
Operating Controls	Continuous Run, Automatic Stop/ Start, Reduced Energy Vent System				Variable			
Rotation Speed - rev/min 50Hz (60 Hz)	1450 (1760)				870-1900	870-1800		
Ambient Temperature Range °C	0 to 45				0 to 40			
Maximum Relative Humidity %	85 non-condensing							
Air Discharge Temp - °C (above ambient)	<8	<10			<8	<10		
<b>FACTORY SETTINGS</b>								
Nominal Pressure -bar	8.0 or 10.0				8.0			
Minimum Pressure Valve - bar	5.5 to 6.0							
Load Pressure - bar (PL)	7.5 or 9.5				8.0			
Unload Pressure - bar (PU)	8.5 or 10.5				8.5			
Servo Valve - bar	9.0 or 11.0				9.0			
Run-on-Time after PU - secs (RT)	60 (8 bar) 90 (10bar)				60			
Run-on-Time to Stop (secs) (ST)	2							
Pressure Display Units (P>)	0 (bar) (1 = psi, 2 = kpa)							
Temperature Display Units (T>)	0 = °C (1 = °F)							
Vacuum Relief Valve	1.5 turns anti-clockwise							
<b>INSTALLATION</b>								
ACE Dimensions D x W x H - mm	825 x 700 x 1512							
Air Outlet Size - Rp	3/4	1		3/4	1			
Minimum Room Volume - m <sup>3</sup>	25	35		25	35			
Air Inlet/Outlet Area - m <sup>2</sup>	0.5							
Ventilation Rate - m <sup>3</sup> /h	3400	4800		3400	4800			
Cooling Air Flow m <sup>3</sup> /h (cfm)	3100 (1825)	4500 (2649)		3100 (1825)	4500 (2649)			
Recommended Air Receiver Capacity - L	272							
<b>COMPRESSOR OIL</b>								
Approved compressor oil	Fluid Force Red 2000 (Mineral) & HPO (Synthetic)							
Oil Capacity - litres	7.0	7.5		7.0	7.5			
<b>ELECTRICAL</b>								
Starter reference 400V 50Hz SD	35233		35234					
Circuit Diagram 400V 50Hz SD	77810		77810					
Starter reference 200-575V 60Hz DOL	35235		35236					
Circuit Diagram 200-575V 60Hz DOL	77821		77811					
Starter reference 400/460V 50/60Hz RS					35237		35238	
Circuit Diagram 400/460V 50/60Hz RS					77822		77812	
Starter reference 200V 50/60Hz RS					35239		35240	
Circuit Diagram 200V 50/60Hz RS					77823		77813	

**3.6 Technical Data HV30-HV45**

Model Number	HV30	HV37	HV45	HV30RS	HV37RS	HV45RS
<b>PERFORMANCE</b>						
F.A.D. litres/sec (cfm) @ 8 bar	86 (182)	99 (210)	122 (259)			
F.A.D. litres/sec (cfm) @ 10 bar	76 (162)	88 (187)	109 (231)			
F.A.D. litres/sec (cfm) @ 6 bar				0-93 (0-197)	0-108 (0-228)	0-132 (0-280)
Noise Level - dBA	73	73		73	73	
Power - kW (hp)	30 (40)	37 (50)	45 (60)	30 (40)	37 (50)	45 (60)
Starter Type	Automatic DOL & Star/Delta			Inverter Soft Start		
Drive Type	Direct					
Operating Controls	Continuous Run, Automatic Stop/Start, Reduced Energy Vent System			Variable		
Rotation Speed - rev/min 50Hz (60 Hz)	1450 (1760)			0-1800	0-1900	0-1900
Ambient Temperature Range °C	0 to 45			0 to 40		
Maximum Relative Humidity %	85 non-condensating					
Air Discharge Temp - °C (above ambient)	<10					
<b>FACTORY SETTINGS</b>						
Nominal Pressure - bar	8.0 or 10.0			8.0		
Minimum Pressure Valve - bar	5.5 to 6.0					
Load Pressure - bar (PL)	7.5 or 9.5			8.0		
Unload Pressure - bar (PU)	8.5 or 10.5			8.5		
Servo Valve - bar	9.0 or 11.0			9.0		
Run-on-Time after PU - secs (RT)	60 (8 bar) 90 (10bar)			60		
Run-on-Time to Stop - secs (ST)	2					
Pressure Display Units (P>)	0 (bar) (1 = psi, 2 = kpa)					
Temperature Display Units (T>)	0 = °C (1 = °F)					
Vacuum Relief Valve	1.5 turns anti-clockwise					
<b>INSTALLATION</b>						
ACE Dimensions D x W x H - mm	1100 x 900 x 1592					
Air Outlet Size - Rp	1-1/2			1-1/2		
Minimum Room Volume - m <sup>3</sup>	60	90		60	90	
Air Inlet/Outlet Area - m <sup>2</sup>	0.6	1.0		0.6	1.0	
Ventilation Rate - m <sup>3</sup> /h	8,300	10,200	11,000	8,300	10,200	11,000
Cooling Air Flow m <sup>3</sup> /h (cfm)	5020 (2955)	6320 (3720)	6550 (3855)	5020 (2955)	6320 (3720)	6550 (3855)
Recommended Air Receiver Capacity - L	500	900		500	900	
<b>COMPRESSOR OIL</b>						
Approved compressor oil	Fluid Force Red 2000 (Mineral) & HPO (Synthetic)					
Oil Capacity - litres	23.0					
<b>ELECTRICAL</b>						
Starter reference 400V 50Hz SD	35135	35133				
Circuit diagram 400V 50Hz SD	77400	77400				
Starter reference 200V 60Hz DOL	35136	35134				
Circuit diagram 200V 60Hz DOL	77401	77401				
Starter reference 200-575V 60Hz DOL	35161					
Circuit diagram 200-575V 60Hz DOL	77428					
Starter reference 400/460V 50/60Hz RS				35126	35127	35128
Circuit diagram 400/460V 50/60Hz RS				77399	77399	77399

## 4 Transportation and Handling

### 4.1 Introduction

Lifting and transportation must only be carried out by authorised persons, fully trained in the use of the equipment employed.

Ensure that all means of transportation and/or lifting equipment are adequate for purpose and are rated to exceed the full load of the unit.

### 4.2 Lifting and Handling (Fig. 4.1 and Fig. 4.2)

A fork lift or pallet truck are the most suitable means of transportation. Pay particular attention to ensure stability to prevent the unit tilting over.



**Fig. 4.1 - ACE HV11-22 Vertical Compressor**

Lift the hypac or compressor and place it in the desired location.



**Fig. 4.2 - ACED HV11-22 Hypac Compressor**

Damage to mountings may occur if you attempt to slide the compressor into position.

Take care when moving units, some models have support rails for motor filters positioned just inside the front base members.

### 4.3 Model Weights

Table 4.1 shows weights for the ACE HV04-HV45 compressors and the hypac range.

**Table 4.1 - Model Weights**

Model	ACE	ACER	ACED	AERD
HV04	181	306	223	348
HV05	186	311	229	354
HV07	197	322	240	365
HV07RS	204	329	247	372
HV11	384	521	446	586
HV15	397	534	459	599
HV18	481	618	543	683
HV22	494	631	556	696
HV11RS	393	528	453	593
HV15RS	406	541	466	606
HV18RS	507	644	569	709
HV22RS	520	657	582	722
HV30	857	-	-	-
HV37	911	-	-	-
HV45	940	-	-	-
HV30RS	909	-	-	-
HV37RS	963	-	-	-
HV45RS	992	-	-	-

All weights in kilograms



### 5 Installation and Commissioning

#### 5.1 Positioning Your Compressor - Basic Requirements

We recommend an approved installation from an authorized Hydrovane Distributor with a service agreement to maintain your compressor.

Position the compressor/hypac in a room of adequate size on a firm surface, level in both planes within five degrees of the horizontal.

Ensure the area has sufficient load-bearing capacity, normally it is not necessary to bolt the unit down.

Sufficient access (1 metre) for all routine service procedures should be provided all around and above the unit.

Site the compressor/hypac away from sources of dirt, coarse solids, abrasive particles, steam, liquids and gaseous impurities.

This is an industrial compressor and is intended for installation in an indoor environment.

Any air connection made to the compressor outlet must be flexible as the base incorporates resilient mountings.

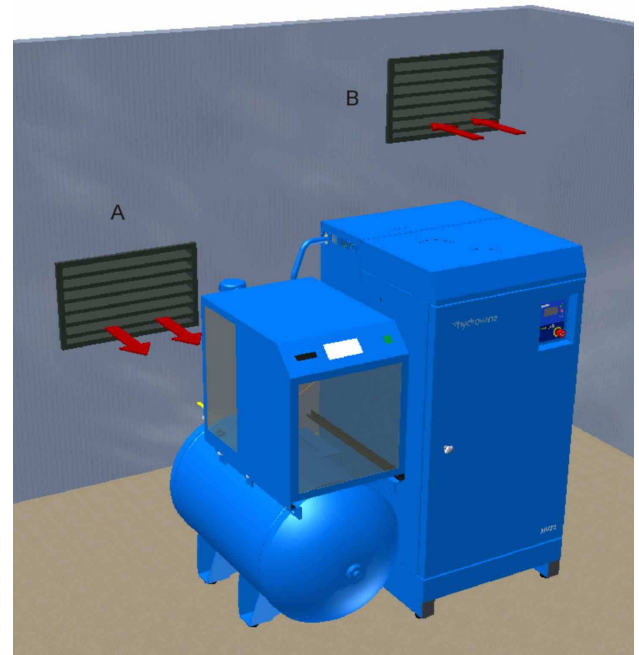

**Fig. 5.1 - Compressor Ventilation**

#### 5.2 Ventilation (Fig. 5.1)

Position the compressor/hypac in a well ventilated location. Do not restrict the air-flow around the compressor or allow the hot air discharge to re-circulate into the compressor intake.

Any cooling-air inlet (A) should be positioned low allowing unrestricted air-flow to the compressor intake. The warm-air outlet (B) should be positioned high, and well away from the inlet, to ensure a positive cooling air-flow through the compressor.

For maximum efficiency and reliability, the compressor should be operated in a moderate ambient temperature. If temperatures frequently fall below 0°C, consult your Hydrovane Distributor. A different grade of oil may be required.

Compressor air intake and exhaust grills have captive nuts fitted as standard to attach ducting.

Air ducting, if fitted, must not cover or restrict the cooling air flow of the compressor. Total resistance of the system must not exceed 5mm w.g. (0.2in. water gauge). If resistance is expected to be greater than 5mm w.g. then fan assistance will be required.

#### 5.3 Electrical Connections

**WARNING !**

**CONNECTION TO, OR INSTALLATION OF, AN ELECTRICAL POWER SUPPLY MUST ONLY BE CARRIED OUT BY AUTHORISED AND QUALIFIED ELECTRICIANS. THEY MUST FULLY UNDERSTAND AND ADOPT CORRECT AND SAFE WORKING PRACTICES. ALL ASPECTS OF THE INSTALLATION MUST MEET THE WIRING REGULATIONS PRESENTLY IN PLACE.**

Before connecting to the mains electrical supply, ensure that the system can sustain the additional electrical load. To ensure reliable low resistance joints, make sure that your incoming supply cables are firmly secured to the starter terminals and that they are of correct size.

**NOTE !** The starter door panel should always be secured by the supplied key for safety reasons and to prevent unauthorized access.

Refer to starter circuit diagrams (located inside the starter door panel) before starting work. The instructions given for earthing, fuses and cable size are important.

Fuses to BS 88 (Type gG) must be used to protect the starter, refer to the sizes specified on the starter circuit diagrams.

Circuit breakers are not recommended since they may not fully protect the starter contacts in an overload condition.

5.4 Electrical Installation (Fig. 5.2)

**WARNING !** 

**BEFORE STARTING WORK, ENSURE THAT THE MAIN-LINE FUSES HAVE BEEN REMOVED FROM THE DISTRIBUTION BOARD. PRECAUTIONS SHOULD BE TAKEN TO PREVENT THEM BEING REFITTED UNTIL THE INSTALLATION IS COMPLETE.**

Starter cables must be connected to the mains electrical supply via a lockable, switched and suitably rated fused isolator. The isolator should be positioned as near as possible to the compressor with clear, unrestricted access.

To access starter terminals, unlock the starter door panel and the front panel on HV30-HV45 with the key provided. Pass incoming cables through the entry hole in the floor for HV04-HV22 or left hand side panel and rear of starter panel for HV30-HV45.

Connect the three mains supply cables to the contactor terminals marked L1, L2 and L3, and connect the earth cable to the earth pin E. Ensure the connections are secure.

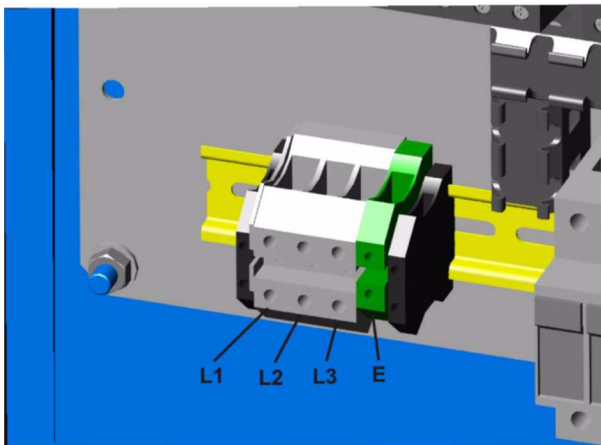

**Fig. 5.2 - Electrical Connections to Starter Terminal**

Cable sizes specified on the circuit diagram are the minimum size to suit a typical installation. If the compressor is located a long way from the isolator and/or the ambient temperature exceeds 35°C, the cable size should be increased.

Refer to IEEE Regulations for electrical equipment installed in buildings to determine the size required, pay particular attention to the circuit diagrams provided.

Check that the transformer fuse is positioned to suit the supply voltage of the installation.

Ensure all electrical connections are tight, high voltage supply to contactors and incoming terminals are critical.

Close the starter door and secure with the key provided before replacing the main line fuses.

5.5 Check Direction of Motor Rotation

**WARNING !** 

**READ HEALTH AND SAFETY PRECAUTIONS BEFORE STARTING COMPRESSOR.**

Ensure that the compressor is filled with approved oil and that all plugs are fitted securely.

Refer to Section 9.6, Access Panel Removal to remove the top panel so that the compressor pressure gauge can be viewed.

With the mains isolator on, press the green start button mounted on the control panel and watch the pressure gauge.

Rotation is correct if the pressure display rises immediately, after a few seconds if no pressure is displayed rotation is incorrect.

**WARNING !** 

**IF ROTATION IS INCORRECT, STOP THE COMPRESSOR IMMEDIATELY. SERIOUS DAMAGE WILL OCCUR IF THE MOTOR IS ALLOWED TO RUN IN REVERSE.**

**ISOLATE THE ELECTRICAL SUPPLY.**

Open the starter door and change over any two of the incoming cables connected to the starter terminals L1, L2 and L3.

Close and lock the starter door to prevent unauthorised access and switch the mains electricity supply on.

Restart the compressor and verify that direction of rotation is correct by observing pressure rise on the compressor gauge.

Replace the top panel and close and lock both front and starter panel doors.

Cooling fan operation is clockwise, single speed HV30-HV45 and all RS units have automatic stop/start cooling fans that cut in at 85°C operating temperature.

Remove the cabinet filter from the lower half of the rear panel to view the cooling fan through the mesh grill.

5.6 Regulated Speed Compressor Installation

Install as instructed for standard fixed speed compressors with the same fuse sizes for a given power rating.

Circuit breakers (Type D) with motor starting characteristics of suitable size may be used to protect the installation.

Starting currents will not exceed 150% motor full load current and will generally be no more than 100% full load current.

Installations must be earthed in accordance with local regulations, the use of RCDs is not recommended.

Water drain, filters or dryers fitted downstream of the compressor discharge must be correctly sited to avoid excessive flow restrictions to ensure stable operation of the speed control system.

### 5.7 RS Operation with other Hydrovane Compressors

Hydrovane RS compressors may be operated efficiently in conjunction with other Hydrovane compressors fitted with automatic stop-start control.

Adjust the RS minimum air line pressure to midway between the maximum and minimum air line pressure settings of the other compressor. The RS compressor will automatically assume the lead compressor role after several cycles.

**NOTE !** If the RS compressor is operated with other Hydrovane standard single speed compressors feeding a common pressure system, the minimum air line pressure of the RS compressor must be limited to the lowest maximum air line pressure of the single speed machine(s). No attempt must be made to increase the operating pressure of the single speed machine(s).

The pressure transducer sensing point is located in a valve housing adjacent to the outlet from the compressor. If the pipework from the compressor to the system is restricted, or prone to excessive pressure fluctuation, rapid speed changes and/or frequent stopping and starting of the motor may occur.

Should this condition arise, consult a Hydrovane Distributor who will arrange to re-site the pressure transducer location.



## 6 General Description

### 6.1 Compressor/Hypac (Fig. 6.1)

This User Manual covers the Hydrovane ACE HV04-HV45 vertical range of compressors. The hypac range contains a compressor and either a receiver or an air dryer or both, depending on the installation required.

The compressor alone is used where air demand is constant and does not exceed the output capacity of the compressor.

An air drier is used to provide dry air (pressure dew point 3°C) for specialised applications.

Where air demand fluctuates a compressor with receiver is used to store large quantities of air. A drier can be combined with the compressor and receiver for applications requiring large volumes of dry air.

Figure 6.1 shows general views of typical units, the compressor assembly is detailed in Para 6.3/ Fig 6.2, the air drier is supplied with its own manual.



**Fig. 6.1 - General Views**

### 6.2 Control Systems

Compressors can be operated either in automatic Stop/Start mode or in continuous run mode.

All units benefit from REVS (Reduced Energy Venting System) to minimise power consumption during operation.

On start up a short delay prevents full pressure delivery to reduce motor power consumed.

With maximum line pressure established the venting system lowers compressor pressure to provide substantial cost savings due to the offload power reduction.

During offload run on time at minimum pressure the compressor will either stop with no air demand or return to onload running if more air is required.

#### Automatic Stop/Start Mode

This is the normal mode of operation giving maximum efficiency and economy for applications with fluctuating air demands. With the auto mode selected, the compressor will load/unload and stop/start automatically in response to air demand.

Motor restarts are set to 10 times per hour for single speed units and 30 times for RS units.

Run-on time to stop can be increased to reduce or limit motor restart frequency to lower levels if required.

#### Continuous Run Mode

When the continuous run mode is selected, the compressor will continue to supply air from full to zero flow rates. In this mode the energy saving benefits of REVS will not be maintained.

#### Regulated Speed Operation

Regulated speed compressors are automatic stop/start operation only.

The Hydrovane Regulated Speed compressor saves energy and operating cost when compared with a fixed speed compressor of similar size. The saving is achieved by automatically regulating the compressor speed to precisely match the compressor output to the system demand.

If the system pressure rises above the unload pressure the electric motor speed will decrease, conversely, if the system pressure falls below the load pressure the motor speed will increase. The speed will vary between load and unload limits dependent upon system demand.

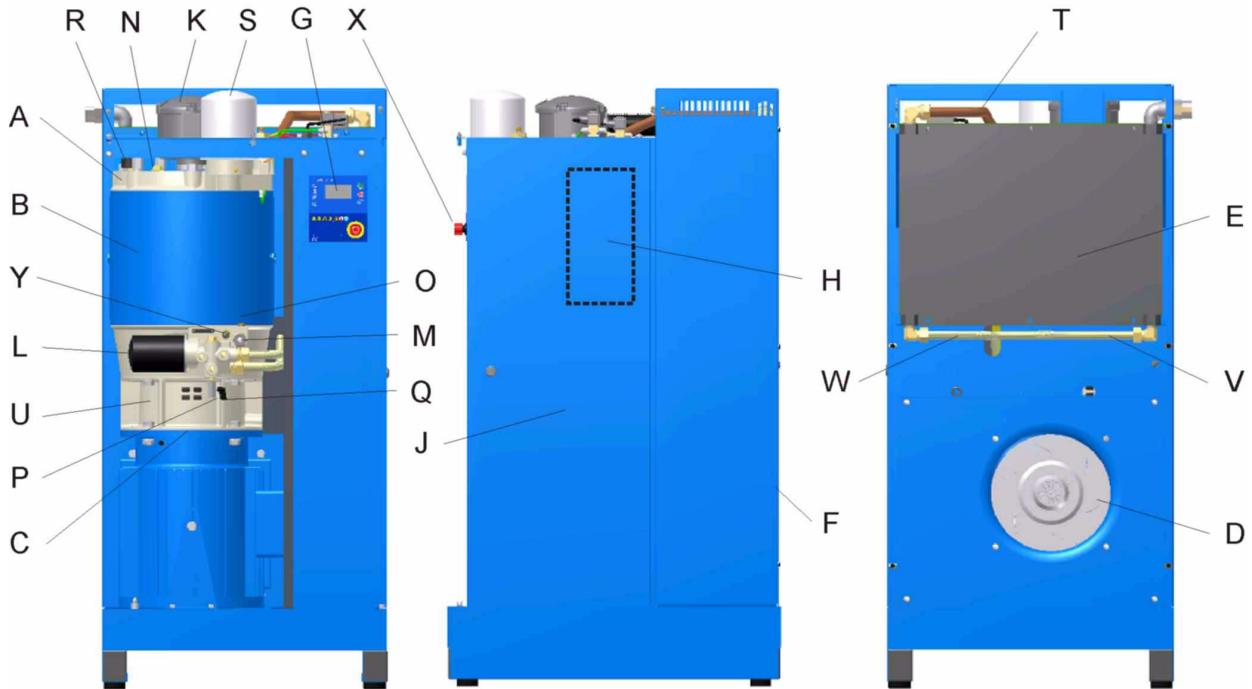

Fig. 6.2 - Compressor Assembly

### 6.3 Compressor Assembly (Fig. 6.2)

The unit comprises of a vertical single stage, oil flooded, rotary, sliding vane compressor driven by an electric motor mounted to a base. It is supplied with control panel, starter, and oil cooler/air aftercooler with all accessories piped in and electrically connected.

The intake cover (A) is assembled directly to the compressor (B) which is fitted to the motor flange (C). A flexible coupling drives the compressor rotor from the motor drive shaft, enclosed inside the bell housing (U). The motor is bolted to the vertical column supported by the base.

An electrically driven, impeller type, horizontally mounted fan (D) is located below the combination oil cooler/air aftercooler matrix (E). This draws cooling air through the air filter (F) and forces it through the cooler matrix.

The compressor electronic controller (G) with an LCD screen is mounted in the starter (J). An emergency stop button (X) is located on the front controller panel.

For RS models, the inverter drive (H) is mounted inside the starter compartment, behind the starter panel door (J).

The compressor air intake is protected by an air intake filter (K), and the oil system is filtered by an oil filter (L). An oil level sight glass (M) is mounted adjacent to the oil filter.

The compressor is filled and topped up with oil via the oil filler (N). The sight glass (M) will be full when oil overflows from the level plug orifice (O).

Oil is drained from the compressor and cooler by removing the drain plug (P) and opening the drain tap (Q).

The compressor pressure gauge (R) is visible when the top panel is removed.

Oil separators (S) located on the compressor top cover ensure air delivered through the minimum pressure valve has a cleanliness of less than 3 ppm (parts per million by weight). Air is delivered through the air delivery pipe (T) to the after cooler (E) before discharge from the unit.

The oil supply to the cooler is through oil feed pipe (V) with the cool oil return through oil return pipe (W). For a quick warm up, a thermal by-pass valve (Y) allows the oil supply to by-pass the cooler on initial start up.

### 6.4 Electronic Controller

Controllers have menu structures that contain all the parameters and settings for safe operation of the compressor.

- P00 User Menu (View Only)
- P10 Customer Menu
- P20 Oil Change Menu
- P21 Service Menu
- P22 Diagnostic Menu
- P30 Drive Menu (RS Only)
- P31 Factory Menu

For safety reasons menu's P20 onwards are reserved for trained personnel and require access codes for entry. The following sections describe in detail the P00 and P10 menu's only.

## 7 Operating Instructions

### 7.1 Introduction

**WARNING !**

**THE COMPRESSOR SHOULD ONLY BE OPERATED BY AUTHORISED PERSONS FULLY TRAINED IN THE STARTING, STOPPING AND EMERGENCY STOP PROCEDURES.**

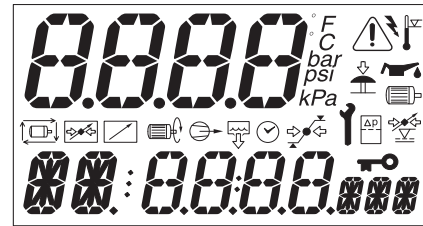

**Fig. 7.1 - Controller Display**

#### 7.1.1 Checking Procedure Before Starting

- (a) Check sight glass is full.
- (b) Check filler, drain/oil level plugs are fitted securely.
- (c) Check for any signs of oil leaks.
- (d) Check air-outlet valve is open.
- (e) Check that the emergency stop button is released.
- (f) Turn mains electricity supply on.

#### 7.1.2 Compressor Operation

When electricity is first switched on the electronic controller (Fig 7.2) displays all symbols and illuminates both green and red LED indicators for three seconds (Fig. 7.1)

The display then shows the software version code for a further three seconds before showing the normal operating display.

Single speed compressors allow two operating modes, automatic stop/start, set as default, or continuous run, refer to Section 8, Adjustments.

Press plus up or minus down button to scroll through available User Menu codes P00 (view only).

- (a) AT - Compressor Temperature.
- (b) PD - Delivery Pressure.
- (c) H1 - Hours Run.
- (d) H2 - Loaded Hours.
- (e) H3 - Hours Remaining to Service.
- (f) SR - Motor Speed (RS Only).
- (g) DC - Drive Current (RS Only).
- (h) DV - Drive voltage (RS Only).
- (i) DP - Drive Power (RS Only).
- (j) VT - Drive Temperature (RS Only).
- (k) DS - Drive Status (RS Only).
- (l) DE - Drive Error (RS Only).
- (m) SP - Percentage Motor Speed (RS Only).
- (n) FS - Drive Switching Frequency (RS Only).
- (o) ED - Software Edition.

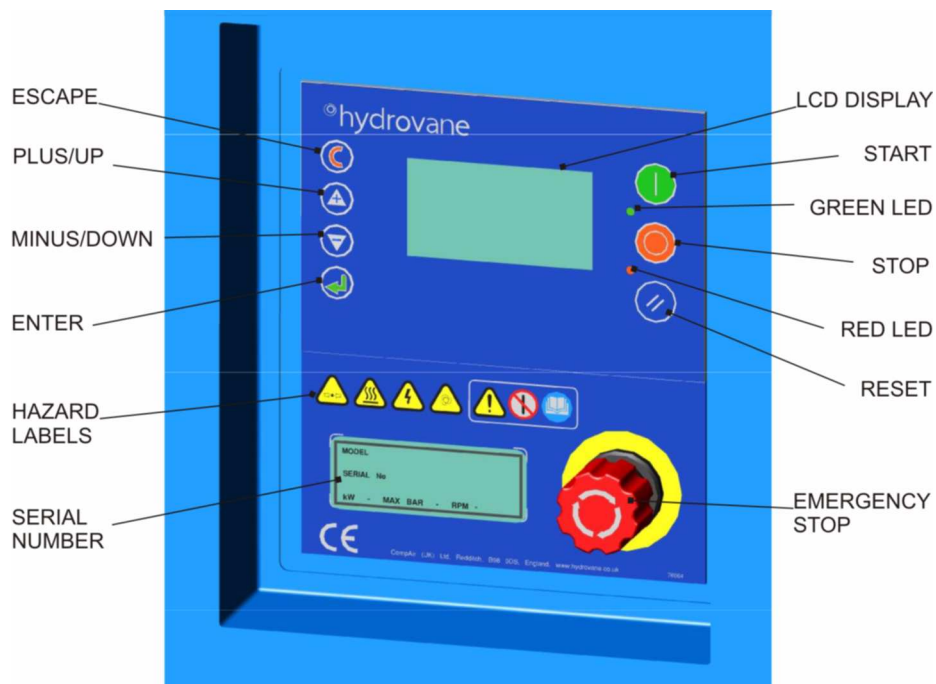

**Fig. 7.2 - Controller**

As a default value the AT - compressor temperature appears in the bottom of the display.

To select and lock other menu items, scroll to the item required, when in view press the ENTER button, a flashing key symbol is displayed.

To cancel the locked selection and flashing key symbol press the ESCAPE (C) or reset button.

During operation, the controller records the total running hours, the hours run on load and counts down to the next service interval.

The service interval is set for 2000 hours when using Fluid Force Red 2000 oil. This interval will be reduced if the unit operates above the recommended temperature.

### 7.1.3 Starting - Automatic Mode

Press the green START button, the compressor will start if system pressure is below the load pressure (PL) set point. On initial start with no pressure in the system, the pressure display will quickly rise to the full delivery pressure. During this period, the green LED will be continuously illuminated.

The compressor will continue to run and pressure will vary within the load/unload (PL/PU) pressure set points to match the system demand.

If system demand reduces and pressure rises to the unload (PU) pressure set point, the REVS (Reduced Energy Venting System) sequence (RT) will begin.

If there is an air demand during the REVS run on time sequence (RT) the compressor returns to full load operation.

If there is no air demand during the REVS run on time sequence (RT) the compressor will stop.

Automatic restart will occur when system pressure falls to the load (PL) pressure set point.

### 7.1.4 Starting - Continuous Mode

Press the green START button, the compressor will start, and run continuously within the load/unload (PL/PU) pressure set points to match system demand.

On initial start with no pressure in the system, the pressure display will quickly rise to the unload (PU) pressure set point. During this period, the green LED will be continuously illuminated.

### 7.1.5 Starting - Regulated Speed

For variable speed models, the starting sequence is the same as that shown for single speed automatic mode except that, instead of the compressor continuing to run and pressure varying within the load/unload (PL/PU) pressure set points, the compressor will continue to run and the speed will vary automatically to match system demand.

With no system demand when running at minimum speed the compressor will stop after the REVS venting sequence (RT).

Automatic restart will occur when system pressure falls to the load pressure (PL) set point.

### 7.1.6 Stopping – All Models

To stop the compressor, press the red STOP button, system pressure will remain high initially, but will fall gradually with the rate of decay depending on system usage.

### 7.1.7 Emergency Stop

If an emergency occurs, press the EMERGENCY STOP button.

The button will lock in the depressed position and stop the compressor immediately.

The red LED on the controller will flash quickly together with display symbols.

Clear any faults that may have occurred. Do not reset until it is safe to do so.

Reset the emergency stop button by twisting clockwise before restart.

Press the RESET button on the controller to cancel the red LED and display symbols.

Operation of the emergency stop button is recorded in the controller error log.

### 7.1.8 Compressor Vent Down

Venting is controlled automatically by the REVS system for either operating mode for all models.

## 7.2 Operational Display Symbols

	Motor running		Power failure auto-restart (optional function)
	Loaded		Remote load or remote pressure regulation active
	Amount of time, timer		Remote start/stop
	Filter, differential pressure		Normal operational mode: Selected item locked as temporary default display
	Pressure set point indication (upper & lower set point indicators displayed independently)		Menu mode: Page item locked (adjustment inhibited)
	Condensate drain active (optional function)		

## 7.3 LED Indicators (Fig 7.2)

STATUS:	Green	°
FAULT	Red	l

The indicator states are shown in Table 7.1.

**Table 7.1 - Compressor Status and LED Indicators**

Compressor State	LED Status °	LED Fault l
Shutdown Error	OFF	FF
Startup Init	OFF	OFF *
Start Inhibit Check	OFF	OFF *
Start Inhibit Condition	OFF	SF
Ready to Start	OFF	OFF *
Blowdown (If Load Request) (Otherwise)	FF IF	OFF * OFF *
Standby	IF	OFF *
Start motor in Star/Delta (If Load Request) (Otherwise)	FF IF	OFF * OFF *
Load Delay (If Load Request) (Otherwise)	FF IF	OFF * OFF *
Load	ON	OFF *
Reload Delay (If Load Request) (Otherwise)	FF IF	OFF * OFF *
Standby Run-on-Time	IF	OFF *
Stop Run-on-Time	SF	OFF *

**Key:**

ON	Illuminated continuously
FF	Fast flash: on/off four times per second
SF	Slow flash: on/off once per second
IF	Intermittent flash: on/off every four seconds
OFF	Extinguished continuously
*	SF for alarm condition



## 8 Adjustments

### 8.1 Compressor Control (Fig. 8.1)

The compressor controller has a Customer Menu (P10) that has parameter settings that can be modified within set limits to suit system requirements.

The controller has a built-in time delay to prevent pressurised restart that inhibits the automated motor start sequence and controls the vent solenoids.

The venting system (REVS) is controlled by solenoid valves mounted on the starter enclosure under the top panel cover.

A normally closed solenoid valve (A) controls compressor delivery pressure using the REVS start system to reduce power.

The normally open solenoid valve (B) vents the compressor during the REVS sequence for offload power savings and after stopping allows quick restart if required.

System pressure is shown on the controller, compressor pressure can only be viewed on the gauge fitted to the intake end cover.

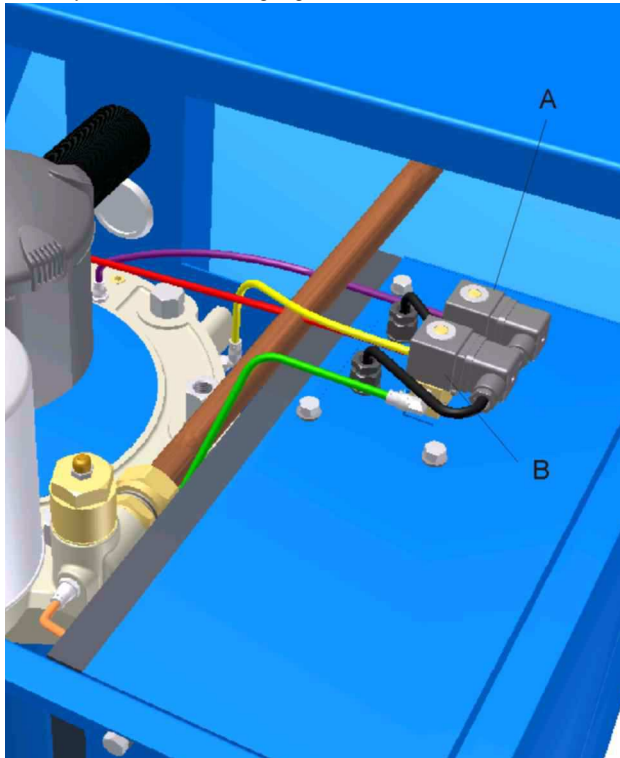

**Fig. 8.1 - Solenoid Locations**

### 8.2 Customer Menu (P10)

To alter default values in Menu P10, or view error codes, press the plus up and minus down buttons together, an access entry screen will be displayed.

Use plus up or minus down button to enter zero for the first flashing character, then press ENTER. The next character flashes, repeat as before and enter zero for characters two and three, but enter 9 for the final character. With all four characters set, press ENTER.

Press plus up or minus down button to scroll through available parameter settings, press ENTER to select.

- (a) PU - Unload pressure
- (b) PL - Load Pressure
- (c) OD - Drain Open Time.
- (d) DI - Drain Interval Time.
- (e) RT - Run on Time after PU.
- (f) P> - Pressure Display Units.
- (g) T> - Temperature Display Units.
- (h) 01-15 - Error Log.

A selected item will flash, press plus up or minus down button to change a value or select an alternative, press ENTER to select.

During changes, if no key activity is detected for one minute, the display will revert to the normal display mode (P00) view only, pressing ESCAPE also causes the display to revert.

The error log menu retains the most recently recorded fault codes and the hours when the fault occurred. The display is view only and will automatically alternate between the two values.

An explanation of the fault codes recorded is given in Section 10, Fault Finding.

### 8.3 Operating Mode (AUT/MO)

Automatic stop/start is set as default, for continuous run on single speed units select MO - MAN, this can be set with the compressor running or stopped.

In menu P21 (access code required), press plus up or minus down button to scroll to AUT, press ENTER, AUT will flash, press plus up or minus down to select MO, press ENTER to select.

### **WARNING !**

**PRESSURE CONTROL ADJUSTMENTS SHOULD BE CONDUCTED BY AUTHORISED HYDROVANE SERVICE ENGINEERS. FAILURE TO COMPLY WITH THIS REQUIREMENT MAY INVALIDATE THE COMPRESSOR WARRANTY.**

### 8.4 Pressure Adjustment - Single Speed

In menu P10, press plus up or minus down button to scroll to either, PU unload pressure or PL load pressure. Press ENTER, with PU or PL flashing, press ENTER, the value will flash, press plus up or minus down button to change the value to the desired pressure and press ENTER to select.

The PL load should be set 0.5 bar below the nominal pressure required and PU unload 0.5 bar above, servo valve pressure is 1.0 bar above the nominal.

Both parameters PL load and PU unload pressure must be set on the controller together with manual servo adjustment, Para 8.6, Servo Valve (Fig. 8.2) to ensure that the compressor functions correctly.

### 8.5 Pressure Control - RS Compressors

The PL load and PU unload pressure may be adjusted from the default settings shown in Section 3, Product Information in the range of 6, 7, 8, 9 or 10 bar.

In menu P10 match the PL load to the nominal bar figure required, the PU unload 0.5 bar above, servo valve pressure is 1.0 bar above the nominal.

Manual servo valve adjustment is necessary to match pressure selected on the controller.

### 8.6 Servo Valve (Fig. 8.2)

The servo valve controls pressure when there is no demand for air, settings shown in Section 3, Product Information are a maximum and must not be exceeded.

Access to the servo valve requires the cabinet front door to be opened and the top cover panel removed, refer to Section 9, Servicing.

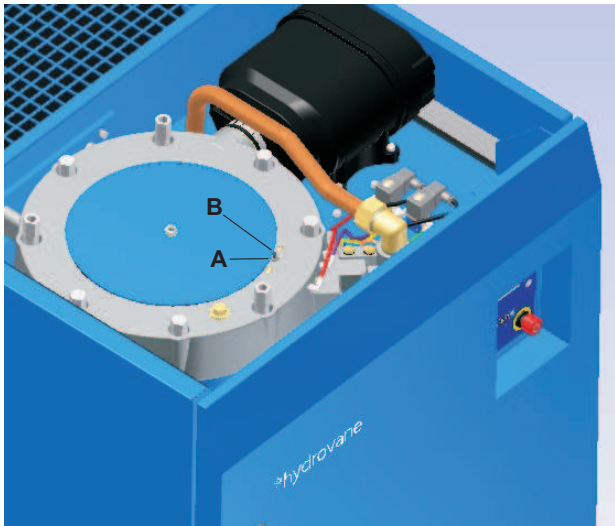

**Fig. 8.2 - Servo Valve**

If the servo needs adjustment or a lower pressure is required then carry out the following procedure.

- (a) Turn the electrical supply on at the isolator, disconnect the air outlet valve from the system and fit an air silencer.
- (b) Select continuous run from P21 Service Menu (access code required), start the compressor open the outlet valve and allow to warm up.
- (c) Release locknut (A), turn grub screw (B) anti-clockwise for two turns and close the outlet valve.
- (d) Screw in grub screw (B) clockwise to increase pressure to the desired setting, allow pressure to stabilise.
- (e) Open and close the outlet valve, allow pressure to stabilise, check the pressure gauge reading.
- (f) If low turn grub screw (B) clockwise to increase or anti-clockwise to decrease pressure.
- (g) With the correct pressure showing on the gauge secure the servo locknut (A).
- (h) Reset the compressor from continuous run back to automatic stop/start operation.

Stop the compressor, isolate from electrical supply and remove air silencer, re-connect the outlet valve to the system.

## 9 Servicing

### 9.1 Introduction

**WARNING !**

**READ HEALTH AND SAFETY PRECAUTIONS BEFORE YOU START ANY SERVICE WORK.**

**SERVICING OF THE COMPRESSOR MUST ONLY BE CARRIED-OUT BY AUTHORISED PERSONS FULLY TRAINED AND COMPETENT IN THE MAINTENANCE, MAINS ELECTRICAL SUPPLY AND STARTER CONTROL EQUIPMENT OF HYDROVANE COMPRESSORS. THEY MUST FULLY UNDERSTAND AND ADOPT CORRECT AND SAFE WORKING PRACTICES.**

If you are unable to carry-out the work safely in the required manner, your Hydrovane Distributor will be pleased to help.

Use genuine parts and approved oils during routine servicing, the following premium service kits are available:

Oil change kit, 2000 hour/12 months, use KO457EP, KO1122EP, or KO3045EP.

Maintenance kit, 4000 hour/2 year, use KM457EP, KM1122EP, or KM3045EP.

Full overhaul/top-up kit, 20000 hour/10 year, use KT457E, KT1122E or KT3045E.

### 9.2 Routine Service Schedule

The work listed in this section must be carried-out at the indicated running-hours, which must be regarded as a maximum. In dusty, hot or humid conditions, more frequent servicing may be necessary.

This section shows the minimum service requirements for your compressor. To ensure that the full maintenance programme is carried out, we recommend that your compressor is regularly serviced by an authorised Hydrovane Distributor.

### 9.3 Servicing (RS)

Servicing intervals and procedures are the same as specified for the standard fixed speed compressor of the same power (kW) rating.

The speed control unit does not require any routine servicing.

After very long periods, it is recommended that the speed control unit capacitors and cooling fan(s) be replaced to ensure continued reliability of the unit. Refer to your Hydrovane Distributor for details.

### 9.4 Check Compressor Operation

Assuming the compressor is serviced correctly, the machine is capable of operating in ambient temperatures up to a maximum of 45°C (40°C RS). At this ambient temperature the oil temperature will be typically 75°C to 85°C.

When the compressor is working, the temperature should be:-

Initial start-up and warm-up period. <70°C

Optimum working temperature. 75 - 85°C

High temperature. 90 -100°C

**Warning ! Consult your Distributor. >107°C**

#### 9.4.1 Check Compressor Pressure

It is necessary to unlock (key provided) and open the hinged front door panel and remove the top panel to view the pressure gauge.

Remove any fixing screws and pull the top panel from the snap fit location pegs or location slots and lift clear of the compressor.

The pressure gauge is located adjacent to the air filter.

#### 9.4.2 Check oil level (Fig. 9.1)

With the compressor stopped check the oil level using the sight-glass (A) fitted near the end of the oil filter. The sight glass should appear full, if only part full or empty top up with approved oil.



**Fig. 9.1 - Oil Level Sight Glass Location**

9.5 Basic Service

**WARNING !** 

**STOP THE COMPRESSOR AND ISOLATE FROM THE MAINS ELECTRICAL SUPPLY. LOCK THE ISOLATOR IN THE OFF POSITION. FIT A SAFETY NOTICE ADVISING THAT WORK IS BEING CARRIED OUT ON THE COMPRESSOR.**

**CLOSE THE AIR OUTLET VALVE TO ISOLATE THE COMPRESSOR FROM THE AIRLINE SYSTEM. FIT A SAFETY NOTICE ADVISING THAT IT IS NOT TO BE OPENED.**

**DO NOT PROCEED UNTIL THE AIR PRESSURE GAUGE READS ZERO !**

**CAUTION !** 

- (1) When changing recommended oil types, it is advisable to flush the Compressor.
- (2) When changing to Fluid Force Clear, the Compressor must be flushed out with Fluid Force Prime.

9.6 Access Panel Removal

With the compressor stopped ensure pressure is vented from the oil cooler/air aftercooler and associated pipework.

Unlock (key provided) and open the hinged front door panel to allow removal of the top panel.

Remove any fixing screws and pull the top panel from the snap fit location pegs or location slots and lift clear of the compressor.

Check that the compressor pressure gauge reads zero.

9.7 Oil Draining and Filter Replacement (Fig. 9.2 and Fig. 9.3)

**WARNING !** 

**AVOID UNNECESSARY CONTACT WITH HOT OIL AND COMPONENTS. GLOVES ARE RECOMMENDED IF DRAINING OIL WHEN THE COMPRESSOR IS HOT!**

9.8 Oil Draining

Remove filler plug (A) (Fig. 9.2) with bonded seal (B) to allow air to enter the compressor to aid drainage.

Place a suitable container below the oil drain point, remove drain plug (A) from the end of the tap (B) (Fig. 9.3), turn the tap and allow oil to drain.

When draining is complete, turn the drain tap to the off position and replace the drain plug, clean away any oil spillages.

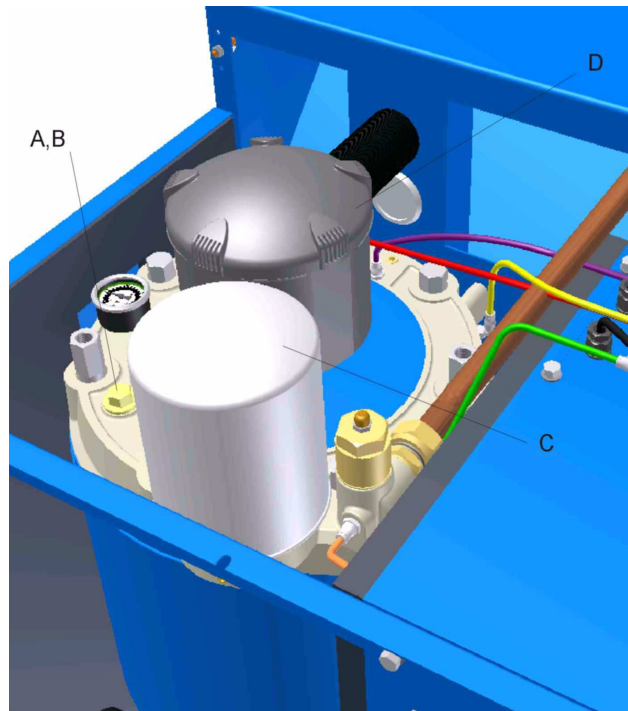

Fig. 9.2 - Oil Filler Plug, Air Filter and Separator Element Location

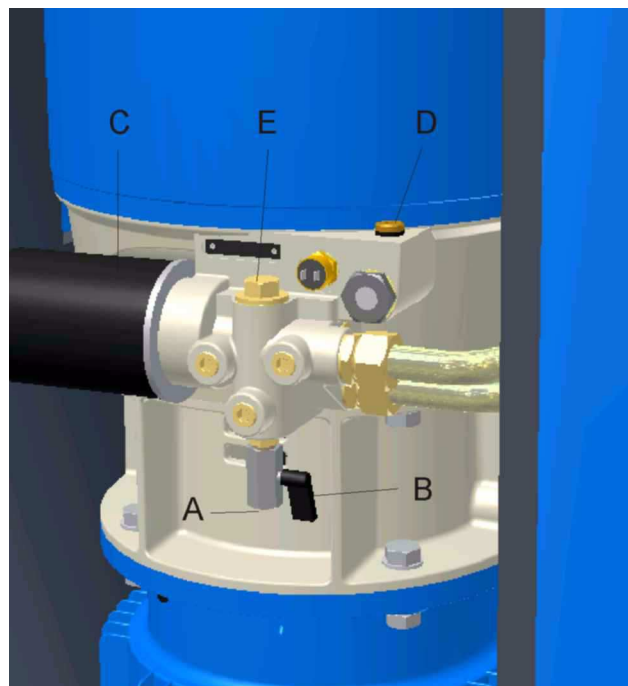

Fig. 9.3 - Oil Drain and Filter Location

9.9 Oil Filter Replacement (Fig. 9.3)

Unscrew oil filter (C) anti-clockwise, minimise spillage from the canister and discard in a safe manner, refer to 9.12.

Using a new filter, smear a small amount of oil onto the seal, screw in clockwise, hand tight only.

### 9.10 Oil filling / Top-up (Fig. 9.3)

Remove and retain the level plug (D) located behind the bypass valve (E) and fill the compressor with approved oil.

When the level is correct, oil will overflow from the level plug. Stop filling, replace the level plug and clean away any spillage.

Refit filler plug (A) Fig. 9.2 and bonded seal (B), renew if damaged, tighten the plug using a suitable spanner. Do not over tighten.

### 9.11 Air Filter Replacement (Fig. 9.2)

Twist the container cap (D) anti-clockwise, lift vertically to expose the element or unclip the cover if located inside the starter door.

Remove the old element and discard in a safe manner and replace with a new element before replacing the cap.

### 9.12 Oil Separator Replacement (Fig. 9.2)

On HV30-HV45 models remove the oil filter first before removing the separators, refer to 9.9.

Unscrew the oil separator(s) (C) anti-clockwise and discard in a safe manner.

Using a new separator(s), smear a small amount of oil onto the seal, screw clockwise, hand tight only.

### 9.13 Clean Oil Cooler/Aftercooler (Fig. 9.4)

With an exposed matrix as shown (A) use low pressure air (2 bar) and brush and blow over the whole area of the matrix (A).

Remove grommets (if fitted) at the top of the rear panel and undo fixing screws that secure it to the rear frame. Ease the rear panel away from the frame and lift it clear. Vacuum up debris from the cooler and surrounding area behind the cabinet filter (B).

All discarded items and waste oil must be disposed of in an approved manner.

### 9.14 Cabinet Air Filter

Remove the disposable filter located in the rear panel by sliding upwards and pull the bottom edge to clear retaining lips. Refit in the reverse sequence.

### 9.15 Panel Refitting

If the oil filter has been replaced, run for compressor for a short time (30 seconds) and re-check the oil level.

Push the top panel onto the snap fit location pegs or location slots and secure with retaining screws if required, close the front panel door and lock with the key provided.

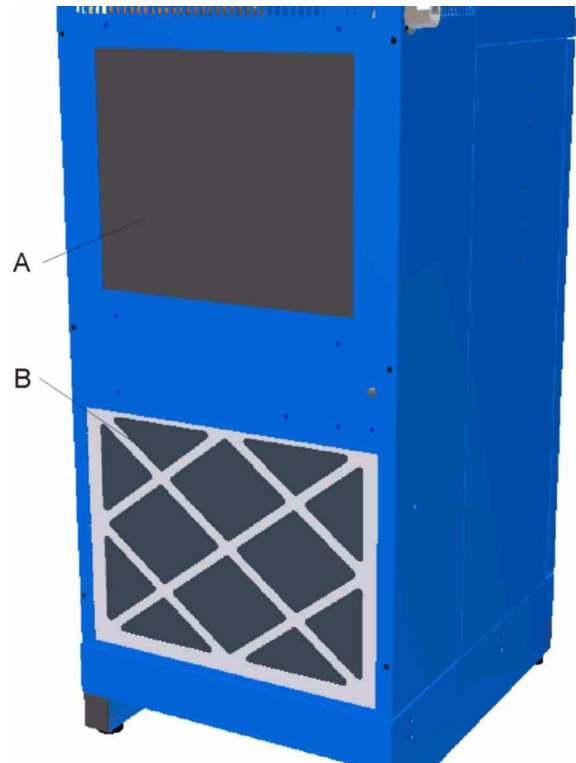

Fig. 9.4 - Matrix Cleaning

### 9.16 Electrical Checks

**WARNING !**

**ISOLATE THE COMPRESSOR FROM THE MAINS ELECTRICAL SUPPLY. LOCK THE ISOLATOR IN THE OFF POSITION. FIT A SAFETY NOTICE ADVISING THAT WORK IS BEING CARRIED OUT ON THE COMPRESSOR.**

Open the starter panel door and remove any terminal covers fitted to contactors and incoming supply terminals.

Check for any signs of overheating and ensure that all electrical connections are tight.

Pay special attention to power connections, cables connected to contactors and incoming terminals and ensure all earthing wiring is present and undamaged.

Close the starter panel door and lock with the key provided to prevent unauthorised access.

### 9.17 Motor Cleaning

Remove dust or dirt from motor bodies and the motor air intake cowls located under the compressor base. Certain models have a replaceable filter fitted to the underside of the base.

On completion of the basic service remove safety notices and switch the mains electricity on and open the outlet valve.

## 9.18 Servicing Requirements

The following preventive maintenance charts cover all Hydrovane compressors using Hydrovane Fluid Force Red 2000, Clear and HPO oils.

The work to be carried out must be done on or before the hours shown for this action, or every 12 months, whichever is soonest.

Tables 9.1 for 2000 hour oil change periods and 9.2 for 4000 hour oil change are shown in entirety, shaded items are Hydrovane Distributor maintenance tasks only.

**NOTE !** Certain items may not be applicable to all units.

### **READ HEALTH AND SAFETY PRECAUTIONS BEFORE STARTING ANY WORK.**

## 9.19 Service Schedule: Fluid Force Red, Clear and HPO Oil

For normal ambient conditions bulk oil temperatures must not exceed 90°C (100°C for HPO oil) when using 2000 hour oil change periods.

In higher ambient conditions using 4000 hour oil change periods HPO oil should not exceed 90°C. In extreme ambients HPO oil should be used at the 2000 hour oil change periods.

If the oil is working above these temperatures the oil life will be significantly reduced.

If changing to Fluid Force Clear flush the compressor with Fluid Force Prime in order to comply with USDA H1 standard.

The service life of the air filter and cabinet filter are an indication only, actual life durability will depend on the operating conditions.

## 9.20 Service Kits

Additional kits available for full product support are as follows:

Cabinet filter kit, 2000 hour/12 months, use KF457E, KF1122E or KF3045E.

Solenoid valve kit, 8000 hour/4 year, use KSVDOL, KSVSD or KSV3045E.

Contactor kit, non scheduled item, use KC457DOL, KC457ERS, KC457ESD, KC1115E, KC15ERS, KC1822E, KC22ERS, KC30E, KC30ERS, KC3745E or KC3745ERS.

Electrical kit, 20000 hour/10 year, use KE457EDOL, KE457ESD, KE457ERS, KE1115E3, KE15ERS, KE1822E, KE22ERS, KE30E, KE30ERS, KE3745E or KE3745ERS.

Wear sleeve kit, 20000 hour/10 year, use KW457E, KW1122E or KW3045E.

Motor bearing kit, 20000 hour/10 year, use KBH132 (HV04), KBV132 (HV05/07), KBV160 (HV11/15), KBV180 (HV18/22).

**Table 9.1 - Service Schedule Fluid Force Red, Clear and HPO (2000 hour change period).**

Maintenance Actions	Install	Daily	Weekly	Every 2000 hrs	Every 4000 hrs	Every 20000 hrs
Site-sufficient access for service	X					
Site-protected from weather	X					
Site-adequate ventilation	X	X	X	X	X	X
Site-ambient temperature within limit	X	X	X	X	X	X
Site-dust free ambient	X	X	X	X	X	X
Check/torque electrical connections	X			X	X	X
Check oil level at filler plug/sight glass	X	X	X	X	X	X
Check correct drive rotation	X					X
Check for air leaks	X		X	X	X	X
Check for oil leaks	X		X	X	X	X
Check air intake filter/clean if necessary	X		X			
Check power on-load	X			X	X	X
Check power off-load	X			X	X	X
Check oil temperature	X		X	X	X	X
Check RSU temperature	X		X	X	X	X
Check servo pressure off-load	X			X	X	X
Check motor gland/cables secure	X			X	X	X
Check motor for damage	X			X	X	X
Check motor/starter for loose connections	X			X	X	X
Check motor cables and earth	X			X	X	X
Check motor for vibration	X			X	X	X
Check flexible oil pipes				X		
Check oil seal for leakage				X	X	
Check drive media/key						X
Check starter contactors					X	
Check motor insulation resistance						X
Check combi cooler matrix			X	X	X	X
Clean any external dirt from compressor	X		X	X	X	X
Clean any external dirt from motor	X		X	X	X	X
Clean cabinet filter			X			
Clean solenoids				X	X	X
Change separator element					X	X
Change 2000 hour oil				X	X	X
Change oil filter				X	X	X
Change air intake filter				X	X	X
Change cabinet filter				X	X	X
Change unloader valve seals					X	X
Change MPV seals					X	X
Change vacuum valve seals					X	X
Change flexible pipes					X	X
Change thermal motor					X	X
Grease motor bearings (if applicable)					X	
Full air end inspection (internal)						X
Clean servo filter						X
Change drive media/key						X
Change oil seal						X
Change pressure gauge						X
Change motor bearings						X
Full operational test/check	X			X	X	X
Filter element fitted to Hypac units only					X	

**Table 9.2 - Service Schedule Fluid Force HPO (4000 hour change period)**

Maintenance Actions	Install	Daily	Weekly	Every 4000 hrs	Every 20000 hrs
Site-sufficient access for service	X				
Site-protected from weather	X				
Site-adequate ventilation	X	X	X	X	X
Site-ambient temperature within limit	X	X	X	X	X
Site-dust free ambient	X	X	X	X	X
Check/torque electrical connections	X			X	X
Check oil level at filler plug/sight glass	X	X	X	X	X
Check correct drive rotation	X				X
Check for air leaks	X		X	X	X
Check for oil leaks	X		X	X	X
Check air intake filter/clean if necessary	X		X		
Check power on-load	X			X	X
Check power off-load	X			X	X
Check oil temperature	X		X	X	X
Check RSU temperature	X		X	X	X
Check servo pressure off-load	X			X	X
Check motor gland/cables secure	X			X	X
Check motor for damage	X			X	X
Check motor/starter for loose connections	X			X	X
Check motor cables and earth	X			X	X
Check motor for vibration	X			X	X
Check flexible oil pipes				X	
Check oil seal for leakage				X	
Check drive media/key				X	X
Check starter contactors					X
Check motor insulation resistance					X
Check combi cooler matrix			X	X	X
Clean any external dirt from compressor	X		X	X	X
Clean any external dirt from motor	X		X	X	X
Clean cabinet filter			X		
Clean solenoids				X	X
Change separator element				X	X
Change 4000 hour oil				X	X
Change oil filter				X	X
Change air intake filter				X	X
Change cabinet filter				X	X
Change unloader valve seals				X	X
Change MPV seals				X	X
Change vacuum valve seals				X	X
Change flexible pipes				X	X
Change thermal motor				X	X
Grease motor bearings (if applicable)				X	
Full air end inspection (internal)					X
Clean servo filter					X
Change drive media/key					X
Change oil seal					X
Change pressure gauge					X
Change motor bearings					X
Full operational test/check	X			X	X
Filter element fitted to Hypac units only				X	

## 10 Fault Finding

### 10.1 Fault Finding

**WARNING !**

The Controller sequential logic monitors and checks compressor status through all stages of the operational cycle. At each stage, the configuration and parameter limits set within the Controller must be met for continued safe operation of the compressor.

If faults occur they appear on the Controller display with a specific code, the last character, E, A or R, identifies the fault type.

### 10.2 Shutdown Error (E)

A shutdown error stops the compressor immediately or by normal stopping sequence, preventing damage or a hazardous condition. The error condition must be located and corrected, press reset to cancel the error and the compressor can restart.

Er 0010 E	Emergency stop
Er 0020 E	Fan motor overtemperature or circuit breaker tripped
Er 0030 E	Motor overload tripped (if fitted)
Er 0080 E	Compressor motor overtemperature
Er 0115 E	Delivery pressure sensor fault
Er 0119 E	Delivery pressure high
Er 0125 E	Delivery temperature sensor fault
Er 0129 E	Delivery temperature high
Er 0135 E	Compressor pressure sensor fault
Er 0131 E	Compressor pressure below set minimum limit of 0.5 bar
Er 0139 E	Compressor pressure high
Er 0821 E	Short circuit on controller analogue or digital supply
Er 0836 E	EMC or controller internal error
Er 0846 E	Delivery pressure sensor range set too low
Er 0856 E	Compressor pressure sensor range set too low
Er 0d01 E	RS485 communication not established
Er 0d02 E	RS485 communication lost
Er 0d03 E	Communication error reported by VSD
Er 0d06 E	VSD error (see P00 - DE)
Er 0d08 E	Safety interlock error (VSD physical start)

### 10.3 Alarm Error (A)

Alarms occur as a warning when normal operating conditions are exceeded, but will not stop the compressor from being started and run.

Er 2118 A	Delivery pressure high
Er 2128 A	Delivery temperature high
Er 2138 A	Compressor pressure high
Er 2816 A	Power failure when controller operational
Er 2d07 A	Drive alarm (see P00 - DE)
Er 2d09 A	Motor overload, compressor unloads until current reduces

### 10.4 Run Inhibit Error (R)

A run inhibit will prevent motor start until the fault is located and corrected. With normal operational status restored, press reset to cancel the error.

Er 3123 R	RSU delivery temperature (AT) below the set temperature run inhibit level.
Er 3137 R	Run inhibited until internal pressure has reduced.
Er 3d04 R	Drive type mismatch
Er 3d05 R	Motor type mismatch

### 10.5 Service Alarm Error (A)

A timer counts down from set values until a routine service is due at 0 that sets off an alarm. A negative value count continues until the timer is reset by maintenance personnel after the service

Er 4804 A	Service due, reset countdown timer
-----------	------------------------------------

### 10.6 Fault Display Symbols

Various examples of symbols that appear on the controller display with fault codes are shown below.

	General fault
	Emergency stop
	Excess pressure
	Power failure
	Above set temperature limit
	Lubrication, oil, oil level
	Dewpoint
	Motor
	Service due, maintenance
	Filter differential, filter service

## 10.7 Controller Menus

In addition to P00 User Menu and P10 Customer Menu further structures are only available to fully trained Hydrovane authorised service engineers and are protected by access codes.

We strongly advise that no attempt is made to access these structures, continued safe operation may be impaired and/or serious damage may occur.

## 10.8 Oil Change Service Menu - P20

Configured for oil changes as part of a service agreement with an authorised Hydrovane Distributor.

## 10.9 Service Engineers Menu - P21

For authorised engineers to install or service compressors as part of an approved installation or maintenance program.

## 10.10 Diagnostic Menu - P22

Allows an authorised technician to check and test the inputs and outputs to the Controller without running the compressor.

## 10.11 Drive Configuration Menu - P30

A parameter set to match inverter drive type and motor control features that maintain operation within safe limits.

## 10.12 Factory Menu - P31

A master configuration menu that retains crucial default setting parameters necessary for controlled safe operation.

If, for any reason, you feel unsure about fault rectification, or any service aspect relating to your Hydrovane compressor, please contact your nearest Hydrovane Distributor.



### Copyright © 2009

All rights reserved. The copyright of this document is the property of Gardner Denver Ltd. No part of this publication may be reproduced, stored in a retrieval system, or transmitted, in any form or by any means, electronic, mechanical, photocopying, recording, or otherwise without the prior written permission of the Technical Publications Department, Gardner Denver Ltd.

Gardner Denver Ltd  
Claybrook Drive  
Washford Industrial Estate  
Redditch  
Worcestershire B98 ODS  
United Kingdom  
Tel +44 (0)1527 525522  
Fax +44 (0)1527 521140

hydrovane USA  
1301 North Euclid Avenue  
Princeton, IL 61356  
United States of America  
Tel (866) 994-8807  
Fax (800) 443-7790

hydrovane Canada  
871 Cranberry Court  
Oakville, Ontario L6L 6J7  
Canada  
Tel (905) 847-0688  
Fax (905) 847-8124

[www.hydrovane.co.uk](http://www.hydrovane.co.uk)  
[www.hydrovane@compair.co.uk](mailto:www.hydrovane@compair.co.uk)  
[www.compair.com](http://www.compair.com)

E-mail: [sales@compair.co.uk](mailto:sales@compair.co.uk)

: